

Elevate Fibre Cable Duct System LSZH

Horizontal Cross

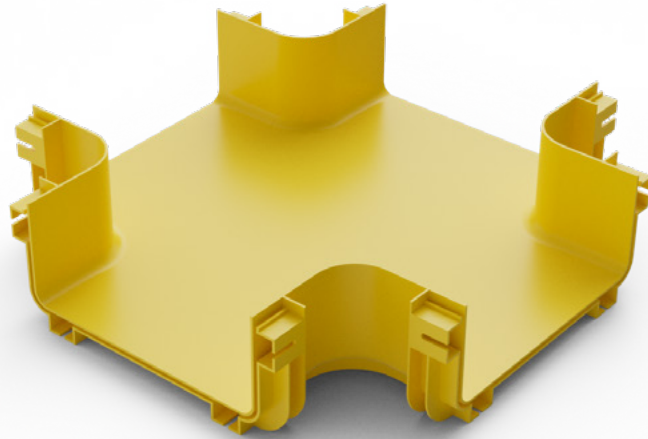

Product Overview

Elevate Fibre Optic Cable Duct Systems are crafted from Low Smoke Zero Halogen (LSZH) material, ensuring superior safety and performance in critical environments. The LSZH material significantly reduces the emission of toxic and corrosive gases in the event of a fire, making it an ideal choice for use in confined spaces such as data centers, tunnels, and public buildings. This feature not only enhances safety but also complies with stringent fire safety regulations.

Available in a comprehensive range of sizes, the Elevate duct system is designed to accommodate various cable volumes, ensuring flexibility and scalability for your network infrastructure. Whether you need to manage a small bundle of cables or a large volume, our duct system provides the perfect fit. Additionally the Elevate solution includes a wide array of accessories, including bends, tees, and junctions, to meet diverse design requirements and facilitate easy installation and maintenance. This versatility ensures that our duct system can be seamlessly integrated into any network layout, providing a reliable and efficient solution for your fibre optic cable management need.

✓ LSZH Flame Retardant

✓ Easy to Assemble

✓ Range of sizes and accessories

✓ UK Design Assistance

Product Specifications

Feature	Values
Colour	Yellow (Pantone 123C)
Material	ABS Plastic
Material Type	LSZH
460-100-CRS	
Width	100mm
Weight	0.93kg
460-150-CRS	
Width	150mm
Weight	1.32kg
460-240-CRS	
Width	240mm
Weight	1.50kg
460-300-CRS	
Width	300mm
Weight	2.18kg
460-360-CRS	
Width	360mm
Weight	2.61kg
460-600-CRS	
Width	600mm
Weight	4.12kg

Product Features

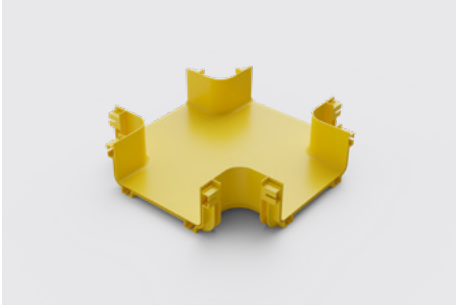

Application - Horizontal Cross

Connection Type - Snap lock

Cover - Yes

Product Drawing

Dimensions shown for 460-100-CRS

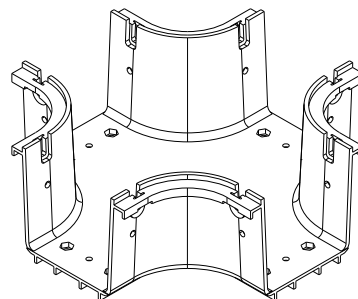
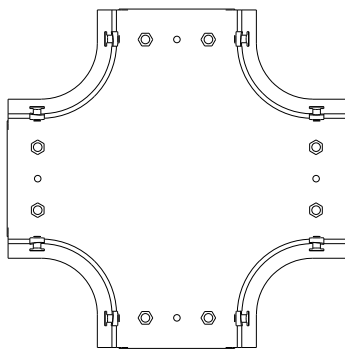
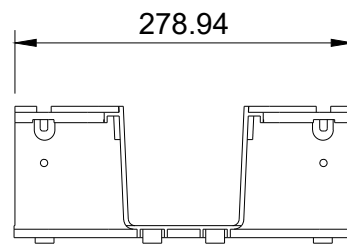
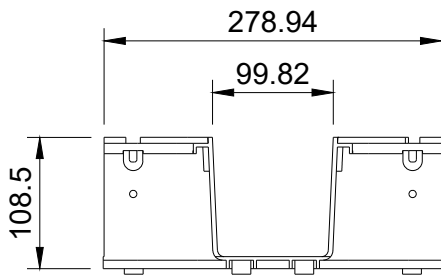

Product Standards

Applicable standard	Description
Directive 2008/98/EC (WFD)	Waste Framework Directive — compliant. Implemented in the UK through the Waste (England and Wales) Regulations 2011 (SI 2011 No. 988).
ECHA SCIP Database	Compliant; product does not contain SVHCs (Substances of Very High Concern) as defined under REACH Article 33(1). Submission obligations met under EU REACH and UK REACH.
Regulation (EU) 2019/1021 (POPs)	EU Regulation on Persistent Organic Pollutants — compliant. For Great Britain, compliance is aligned with the Persistent Organic Pollutants (Amendment) (EU Exit) Regulations 2020 (SI 2020 No. 1355).
Directive 2011/65/EU (RoHS II)	Restriction of the Use of Certain Hazardous Substances in Electrical and Electronic Equipment — compliant. Applies within EU member states.
Directive (EU) 2015/863 (RoHS III)	Amending Directive 2011/65/EU to add four phthalates (DEHP, BBP, DBP, DIBP) to Annex II — compliant.
UK SI 2012 No. 3032	The Restriction of the Use of Certain Hazardous Substances in Electrical and Electronic Equipment Regulations 2012 (UK RoHS) — compliant for Great Britain. Retained EU law, as amended by the Product Safety and Metrology (Amendment etc.) (EU Exit) Regulations 2019.

Part Number Table

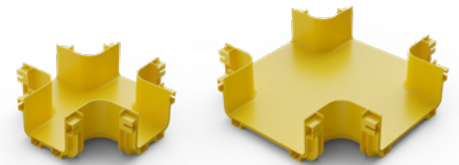

Part Number	Description
460-100-CRS	Elevate Horizontal cross 100mm Wide
460-150-CRS	Elevate Horizontal cross 150mm Wide
460-240-CRS	Elevate Horizontal cross 240mm Wide
460-300-CRS	Elevate Horizontal cross 300mm Wide
460-360-CRS	Elevate Horizontal cross 360mm Wide
460-600-CRS	Elevate Horizontal cross 600mm Wide